

4X  $\phi$  .344 THRU  
 $\square$   $\phi$  .531

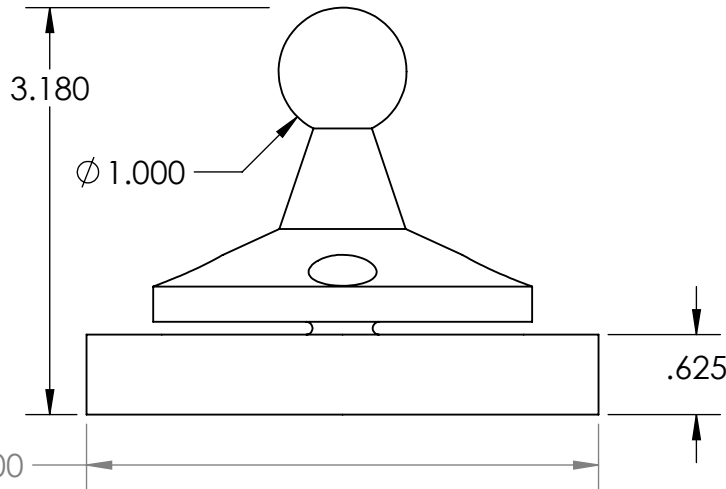

8X  $\phi$  .344 THRU ALL  
 $\square$   $\phi$  .480

4X  $\phi$  .272 THRU ALL  
 5/16-24 UNF THRU ALL

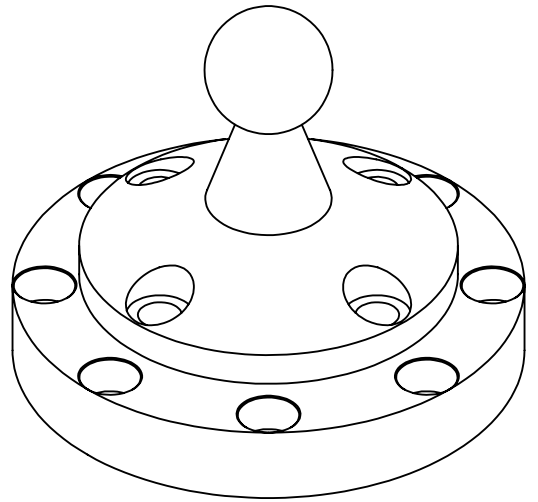
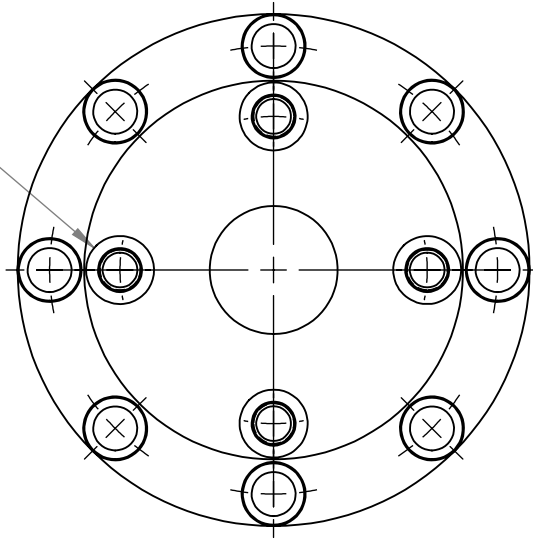
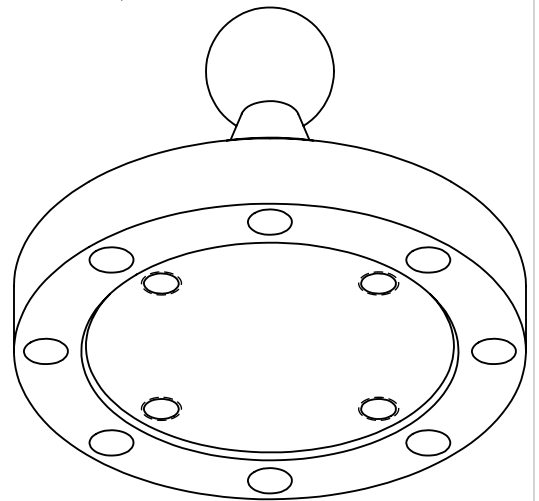
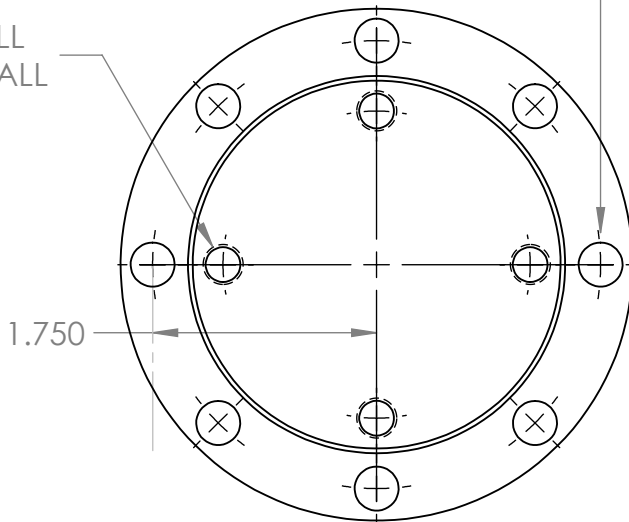

**PROPRIETARY AND CONFIDENTIAL**  
 THE INFORMATION CONTAINED IN THIS DRAWING IS THE SOLE PROPERTY OF <INSERT COMPANY NAME HERE>. ANY REPRODUCTION IN PART OR AS A WHOLE WITHOUT THE WRITTEN PERMISSION OF <INSERT COMPANY NAME HERE> IS PROHIBITED.

		DIMENSIONS ARE IN INCHES TOLERANCES: FRACTIONAL $\pm$ ANGULAR: MACH $\pm$ BEND $\pm$ TWO PLACE DECIMAL $\pm$ THREE PLACE DECIMAL $\pm$		NAME	DATE	<b>AUT4000</b>
		MATERIAL		DRAWN		
		FINISH		CHECKED		
NEXT ASSY	USED ON			ENG APPR.		
APPLICATION		DO NOT SCALE DRAWING		MFG APPR.		
				Q.A.		
				COMMENTS:		
				SCALE: 1:2	WEIGHT:	SIZE   DWG. NO.   REV.   SHEET 1 OF 1

Flange Mounted Authenticator 1.00